



*Lovejoy Cone-Flex couplings consists of sets of resilient "Cone-Flex" rings with pins & nuts and two flanged hubs of graded cast iron. These "Cone-Flex" rings are specially shaped to permit the rubber to deflect in all directions and give over four times torsional flexibility as compared to a plain bush.*

**UNMATCHED SIMPLICITY :**

Easy to assemble & disassemble. With pins removed, the equipment can run independently for no load. Flanged hub can be withdrawn upwards without disturbing original alignment.

**NO LUBRICATION :**

"Cone-Flex" couplings do not require lubrication of any kind whatsoever.

**SIZE AND COST :**

High torque capacity for compact size and low weight.

**SIMPLE / EASY MAINTENANCE :**

No complicated mechanism to demand adjustment or maintenance. Inspection and replacement of "Cone-Flex" rings are easy and can be quickly fitted without dismantling or moving either of coupled shafts.

**LOW OPERATIONAL COST :**

Only wear part is low cost "Cone-Flex" rings make the coupling economical in long run.

**SMOOTH & QUIET OPERATION :**

Reduces vibrations and noise arising from severe torque fluctuations.

"Cone-Flex" couplings are suitable in ambient temperature upto 70° C.

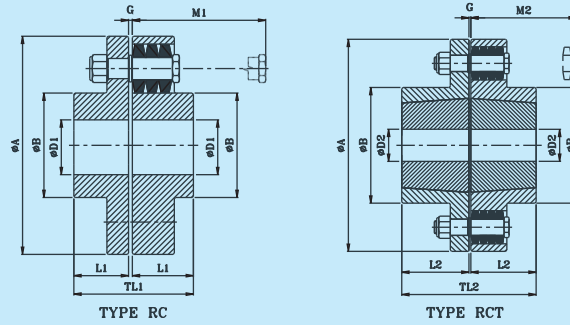

### TECHNICAL DATA

Type	Size	POWER RATING						Max. Speed RPM	ØD1(RC)		#ØD2(RCT)		Dimensions								Wt. in Kg (Min. Bore)		M.I. (WR <sup>2</sup> ) Kg m <sup>2</sup> (Min. Bore)			
		Synthetic Rubber		Polyurethane		HTrans			Min. Bore	Max. Bore	Min. Bore	Max. Bore	# Bush Size	ØA	ØB	L1	L2	G	TL1	TL2	RC	RCT	RC	RCT		
		KW @ 100 RPM	Rated Torque Nm	KW @ 100 RPM	Rated Torque Nm	KW @ 100 RPM	Rated Torque Nm																			
RC	020	0.56	50	0.84	75	1.40	125	6500	12	22	-	-	-	89	35	33	-	3	69	-	30	-	1.4	-	0.0015	-
	030	1.2	110	1.8	165	3.0	275	5470	12	32	-	-	-	127	51	41	-	3	85	-	28	-	3.7	-	0.0078	-
	038	2.0	190	3.0	285	5.0	475	5260	15	40	-	-	-	132	64	48	-	3	99	-	22	-	4.2	-	0.0095	-
RC/RCT	042	3.0	290	4.5	435	7.5	725	4750	15	44	12	32	1215	146	70	56	38	3	115	79	14	32	5.6	5	0.0144	0.0163
	048	5.0	480	7.5	720	12.5	1200	4050	21	52	16	42	1615	171	81	61	38	3	125	79	28	52	6.4	9	0.0357	0.0346
	058	8.0	760	12.0	1140	20	1900	3600	21	62	14	50	2017	193	97	68	45	3	139	93	24	52	13	12	0.0588	0.0567
	070	11.0	1000	17	1500	28	2500	3220	21	74	19	60	2525	216	117	76	64	3	155	130	23	28	19	17	0.0980	0.0951
	075	27	2600	41	3900	68	6500	2730	28	80	16	60	2525	254	127	88	64	3	179	131	50	28	34	33	0.2882	0.2827
	085	37	3500	56	5250	93	8750	2480	28	92	35	75	3030	279	147	100	76	3	203	155	38	60	45	37	0.4337	0.4237
	105	56	5300	84	7950	140	13250	2100	34	114	35	90	3535	330	180	117	89	3	237	181	25	54	67	59	0.8767	0.8529
	120	94	9000	141	13500	235	22500	1880	61	130	40	100	4040	370	206	132	102	6	270	210	48	78	95	95	1.9162	1.8753
	135	128	12223	192	18334.5	320	30557.5	1660	67	144	55	110	4545	419	230	147	114	6	300	235	35	68	128	120	3.1724	3.1032
	150	167	16000	251	24000	418	40000	1520	82	160	70	125	5050	457	256	165	127	6	336	260	16	55	154	141	4.6277	4.4951
RC	170	262	25000	393	37500	655	62500	1300	96	184	-	-	-	533	292	188	-	6	382	-	48	-	249	-	10.5670	-
	190	360	34377	540	51565.5	900	85942.5	1170	122	206	-	-	-	597	330	211	-	6	428	-	28	-	304	-	17.0054	-
	215	471	45000	707	67500	1178	112500	1050	135	230	-	-	-	660	368	237	-	6	480	-	10	-	392	-	26.1883	-
	240	788	75248	1182	112872	1970	188120	800	152	254	-	-	-	737	407	264	-	6	534	-	43	-	578	-	50.1718	-
	265	1047	100000	1571	150000	2618	250000	700	165	286	-	-	-	826	457	292	-	6	590	-	15	-	775	-	81.8464	-

- Notes :
- Maintain gap G at the time of assembly
  - For vertical installation contact RATHI.
  - # Available only with Taper Bore, without Taper Bush.

Axial Misalignment : Size 020 to 058 : 2 mm ( ± ), Size 070 to 135 : 3 mm ( ± ), Size 150 to 215 : 2 mm ( ± ), Size 240 to 265 : 1.5 mm ( ± )

Angular Misalignment : Size 020 to 135 : 1° , Size 150 to 265 : 0.5°

Radial Misalignment : Size 020 : 0.3 mm ( ± ), Size 030 to 042 : 0.4 mm ( ± ), Size 048 to 058 : 0.5 mm ( ± ), Size 070 to 075 : 0.6 mm ( ± ), Size 085 to 105 : 0.7 mm ( ± ), Size 120 : 0.9 mm ( ± ), Size 135 to 170 : 0.11 mm ( ± ), Size 190 to 215 : 0.15 mm ( ± ), Size 240 to 265 : 0.18 mm ( ± ),

### SPARE PARTS

Type RC			Type RCT				Pins and Nuts			Cone Rings	
Size	Pin Half Part No.	Bush Half Part No.	Size	Bush Size	Pin Half Part No.	Bush Half Part No.	Pin Part No.	Nut Size	No/per Coupling	Part No.	No/per Coupling
RC-020	RC020/1	RC020/2	-	-	-	-	GC 3/4" /3/5	M 8	6	GC 3/4" /4	18
RC-030	RC030/1	RC030/2	-	-	-	-	GC 1" /3/5	M 10	4	GC 1" /4	12
RC-038	RC038/1	RC038/2	-	-	-	6			18		
RC-042	RC042/1	RC042/2	RCT-042	1215	RCT042/1	RCT042/2	GC 1 3/4" /3/5	M 12	8	GC 1 3/4" /4	24
RC-048	RC048/1	RC048/2	RCT-048	1615	RCT048/1	RCT048/2			6		18
RC-058	RC058/1	RC058/2	RCT-058	2017	RCT058/1	RCT058/2			8		24
RC-070	RC070/1	RC070/2	RCT-070	2525	RCT070/1	RCT070/2			10		30
RC-075	RC075/1	RC075/2	-	-	-	-			8		32
RC-085	RC085/1	RC085/2	RCT-085	3030	RCT085/1	RCT085/2	GC 2 3/4" /3/5	M 20	10	GC 2 3/4" /4	40
RC-105	RC105/1	RC105/2	RCT-105	3535	RCT105/1	RCT105/2	12		48		
RC-120	RC120/1	RC120/2	RCT-120	4040	RCT120/1	RCT120/2	GC 4 1/4" /3/5	M 24	10	GC 4 1/4" /4	40
RC-135	RC135/1	RC135/2	RCT-135	4545	RCT135/1	RCT135/2			12		48
RC-150	RC150/1	RC150/2	RCT-150	5050	RCT150/1	RCT150/2			14		56
RC-170	RC170/1	RC170/2	-	-	-	-	GC 6 1/4" /3/5	M 36	10	GC 6 1/4" /4	40
RC-190	RC190/1	RC190/2	-	-	-	-			12		48
RC-215	RC215/1	RC215/2	-	-	-	-			14		56
RC-240	RC240/1	RC240/2	-	-	-	-	GC 9" /3/5	M 48	12	GC 9" /4	48
RC-265	RC265/1	RC265/2	-	-	-	-			14		56

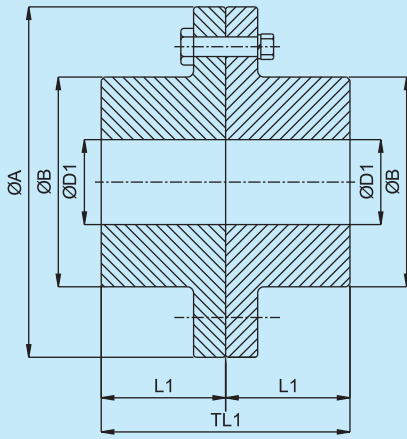

**TYPE - RR**

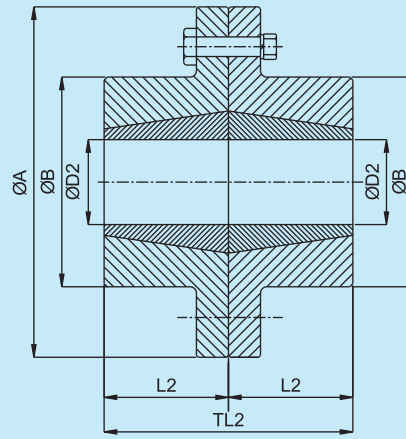

**TYPE - RRT**

Rathi Rigid Couplings are robust, simple & ideal for exactly aligned shafts. They are torsionally stiff & backlashfree. Type RR permits larger finish bores in both halves.

### TECHNICAL DATA

Coupling Type	Size	"kW at 100 RPM"	Torque Nm	Max. Speed RPM	RR		RRT			ØA	ØB	L1	TL1	L2	TL2	Wt. in Kg. (Min. Bore)		M.I. (WR <sup>2</sup> ) Kg. m <sup>2</sup> (Min. Bore)	
					Ø D1		Ø D2		RR							RRT	RR	RRT	
					Min. Bore	Max. Bore	Min. Bore	Max. Bore #											Bush Size
RR	020	1.06	101	6500	12	22	-	-	-	89	35	33	66	-	-	1.6	-	0.002	-
RR/RRT	030	2.30	220	5470	12	32	10	25	1008	127	51	41	82	23	46	3.2	2.8	0.004	0.004
	038	4.80	458	5260	15	40	10	28	1108	132	64	48	96	23	46	4.1	3.6	0.006	0.006
	042	6.40	611	4750	15	44	12	32	1215	146	70	56	112	38.1	76.2	5.6	5	0.008	0.008
	048	9.63	920	4050	21	52	16	42	1615	171	81	61	122	38	76	9.3	8.3	0.024	0.023
	058	16.90	1614	3600	21	62	14	50	2017	193	97	68	136	47	94	12	10.7	0.04	0.038
	070	29.90	2855	3220	21	74	16	60	2525	216	117	76	152	63.5	127	18	16	0.07	0.067
	075	36.50	3485	2730	28	80	16	60	2525	254	127	88	176	68	136	32	30	0.18	0.177
	085	53.40	5099	2480	28	92	24	75	3030	279	147	100	200	76	152	44	39.3	0.28	0.260
	105	100.0	9549	2100	34	114	35	90	3535	330	180	117	234	89	178	69	61	0.59	0.56
	120	149.0	14228	1880	61	130	40	100	4040	370	206	132	264	102	204	109	97	1.42	1.36
	135	213.0	20340	1660	67	144	55	115	4545	419	230	147	294	114.3	228.6	145	129	2.35	2.25
RR	150	292.0	27884	1520	82	160	70	127	5050	457	256	165	330	127	254	186	166	3.48	3.33
	170	470.0	44882	1300	96	184	-	-	-	533	292	188	376	-	-	350	-	9.52	-
	190	575.0	54908	1170	122	206	-	-	-	597	330	211	422	-	-	475	-	14.2	-
	215	750.0	71620	1050	135	230	-	-	-	660	368	237	474	-	-	640	-	22.8	-

# For detail information about Taper Bush bore, please refer Taper Bush catalogue.  
 ● For vertical installation contact RATHI.

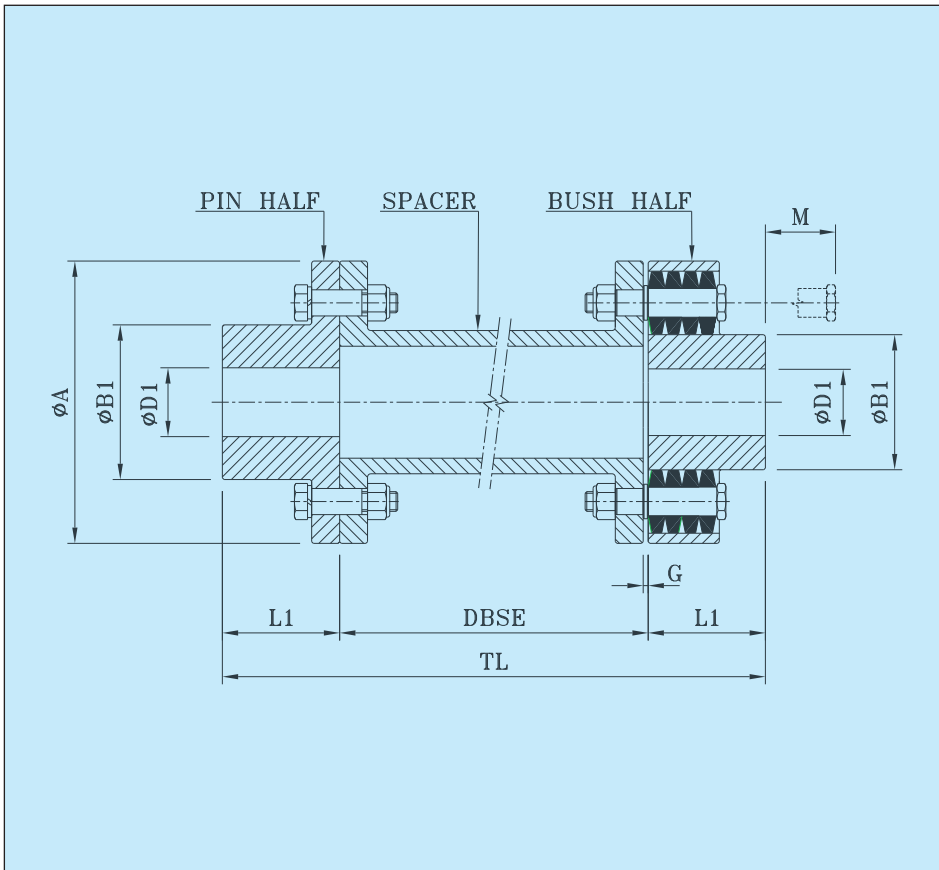

Spacer Type "Cone-Flex" coupling is suitable where distance between shaft ends (DBSE) is large. The spacer member is radially removable without disturbing shaft alignment. Flexible element can be installed without disturbing the hub.

## TECHNICAL DATA

Coupling Size	kW at 100 rpm	Torque Nm	Max. Speed rpm	Bore		Dimensions						
				Min.	Max.	$\phi A$	$\phi B1$	L1	G	DBSE	TL	M
RCS - 020	0.56	50	6500	12	20	89	35	33	3	100	166	30
RCS - 030	1.2	110	5470	12	30	127	51	41			206	
RCS - 038	2.0	190	5260	15	38	132	64	48			246	
RCS - 042	3.0	290	4750	15	42	146	70	56			182	28
RCS - 048	5.0	480	4050	21	48	171	81	61			222	
RCS - 058	8.0	760	3600	21	58	193	97	68			262	24
RCS - 070	11.0	1000	3220	21	70	216	117	76			276	
											140	196
									180	236		
										276	14	
										212		
										252	28	
										292		
										222	24	
										262		
										302	23	
										236		
										276	23	
										316		
										252	23	
										292		
										332		

- All dimensions are in mm unless otherwise specified.
- For vertical installation contact RATHI.

In view of our constant endeavour to improve quality of our products, we reserve the right to alter or change specifications without prior notice. This document is the intellectual property of Rathi Transpower Pvt. Ltd. and subject to copyright.



**Rathi Transpower Pvt Ltd**  
Gaia Apex, S. No. 33/2D, Viman Nagar  
Pune 411 014, (INDIA)  
Phone : 91-20-30517201  
Fax : 91-20-30517212  
E-mail : enquiry@rathigroup.com  
Website : www.rathicouplings.com

Distributor